

SAMPLE PAPER - 5

Class 12 - Physics

Time Allowed: 3 hours

Maximum Marks: 70

General Instructions:

1. There are 35 questions in all. All questions are compulsory.
2. This question paper has five sections: Section A, Section B, Section C, Section D and Section E. All the sections are compulsory.
3. Section A contains eighteen MCQ of 1 mark each, Section B contains seven questions of two marks each, Section C contains five questions of three marks each, section D contains three long questions of five marks each and Section E contains two case study based questions of 4 marks each.
4. There is no overall choice. However, an internal choice has been provided in section B, C, D and E. You have to attempt only one of the choices in such questions.
5. Use of calculators is not allowed.

Section A

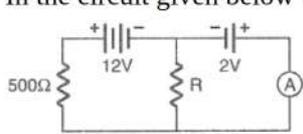
1. When n-type semiconductor is heated: [1]
 - a) number of electrons and holes increase equally
 - b) number of electrons increases while that of holes decreases
 - c) number of electrons and holes remain same
 - d) number of holes increases while that of electrons decreases
2. In the circuit given below the ammeter reading is zero. What is the value of the resistance R? [1]

The circuit diagram shows a single loop. On the left vertical wire, there is a 500Ω resistor. At the top, there is a 12V battery with its positive terminal on the left and negative on the right. On the right vertical wire, there is an ammeter labeled 'A'. At the bottom, there is a 2V battery with its negative terminal on the left and positive on the right. A resistor labeled 'R' is connected between the top and bottom wires, positioned between the 12V battery and the 2V battery.

 - a) 50 Ω
 - b) 400 Ω
 - c) 200 Ω
 - d) 100 Ω
3. Which of the following is incorrect statement? [1]
 - a) the magnification produced by a convex mirror is always less than one
 - b) a virtual, erect, same-sized image can be obtained using a plane mirror
 - c) a real, inverted, same-sized image can be formed using a convex mirror
 - d) a virtual, erect, magnified image can be formed using a concave mirror
4. For a p-type semiconductor, which of the following statements is true? [1]
 - a) Electrons are the majority carriers and trivalent atoms are the dopants.
 - b) Holes are the majority carriers and trivalent atoms are the dopants.

c) Holes are the majority carriers and pentavalent atoms are the dopants.

d) Electrons are the majority carriers and pentavalent atoms are the dopants.

5. An uncharged capacitor with a solid dielectric is connected to a similar air capacitor charged to a potential of V_0 . [1]
If the common potential after sharing of charges becomes V , then the dielectric constant of the dielectric must be:

a) $\frac{V}{V_0}$

b) $\frac{V_0}{V}$

c) $\frac{(V_0 - V)}{V}$

d) $\frac{(V_0 - V)}{V_0}$

6. To convert a galvanometer into an ammeter, we connect: [1]

a) high resistance in parallel

b) low resistance in parallel

c) high resistance in series

d) low resistance in series

7. Magnetic Flux linked with a coil is $\phi = 5t^2 + 2t + 3$, where t is in s and ϕ is in Wb. At time $t = 1$ s, the value of induced emf is: [1]

a) 12 V

b) 14 V

c) 1.2 V

d) 6 V

8. The Bohr model for the H-atom relies on the Coulombs law of electrostatics. Coulomb's law has not directly been verified for very short distances of the order of angstroms. Supposing Coulomb's law between two opposite charge $+q_1, -q_2$ is modified to: [1]

$$|\vec{F}| = \frac{q_1 q_2}{(4\pi\epsilon_0) r^2}, r \geq R_0$$

$$= \frac{q_1 q_2}{4\pi\epsilon_0 R_0^2} \left(\frac{R_0}{r}\right)^n, r \leq R_0$$

Calculate in such a case, the ground state energy (in eV) of a H-atom, if $\mathcal{E} = 0.1$, $R_0 = 0.1$ A.

a) -23.2 eV

b) -5.9 eV

c) -11.4 eV

d) -17.3 eV

9. An observer can see through a pin-hole the top end of a thin rod of height h , placed as shown in the figure. The beaker height is $3h$ and its radius h . When the beaker is filled with a liquid up to a height $2h$, he can see the lower end of the rod. Then the refractive index of the liquid is [1]

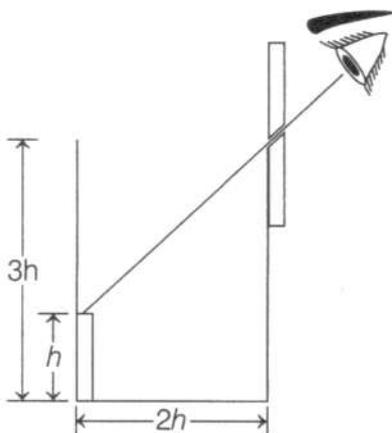

a) $\sqrt{\frac{5}{2}}$

b) $\sqrt{\frac{3}{2}}$

c) $\frac{3}{2}$

d) $\frac{5}{2}$

10. The number of electrons for one coulomb of charge is [1]

a) 6.25×10^{19}

b) 6.25×10^{23}

c) 6.25×10^{21}

d) 6.25×10^{18}

11. For forward biasing a p-n junction, the positive terminal of the battery is connected to [1]

a) n-type crystal

b) either p-type or n-type crystal

c) p-type crystal

d) neither p-type nor n-type crystal

12. The plane faces of two identical plano-convex lenses, each having focal length of 40 cm, are placed against each other to form a usual convex lens, The distance from this lens at which an object must be placed to obtain a real, inverted image with magnification one is: [1]

a) 160 cm

b) 40 cm

c) 80 cm

d) 20 cm

13. When 1 centimetre thick surface is illuminated with light of wavelength λ , the stopping potential is V . When the same surface is illuminated by the light of wavelength 2λ , the stopping potential is $\frac{V}{3}$. The threshold wavelength for the metallic surface is: [1]

a) 4λ b) 6λ c) $\frac{4\lambda}{3}$ d) $\frac{8\lambda}{3}$

14. Equal charges are given to two conducting spheres of different radii. The potential will [1]

a) be more on the bigger sphere

b) be equal on both the spheres

c) be less on the smaller sphere

d) depend on the radii of the sphere

15. If two coherent sources are placed at a distance 3λ from each other symmetric to the centre of the circle shown in the figure, then number of fringes shown on the screen placed along the circumference is: [1]

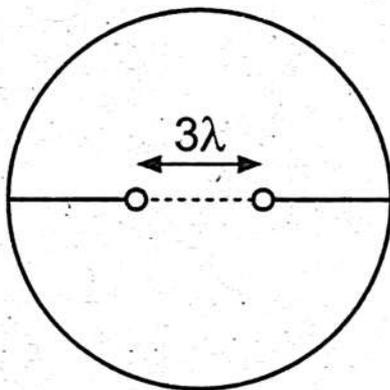

a) 16

b) 8

c) 12

d) 4

16. **Assertion:** Heavy water is used as moderator in nuclear reactor. [1]

Reason: When two bodies having approximately same mass undergo an elastic collision, energy transfer is maximum.

a) Assertion and reason both are correct statements and reason is correct explanation for assertion.

b) Assertion and reason both are correct statements but reason is not correct explanation for assertion.

c) Assertion is correct statement but reason is wrong statement.

d) Assertion is wrong statement but reason is correct statement.

17. **Assertion (A):** Electromagnetic radiations exert pressure. [1]
Reason (R): Electromagnetic waves carry both momentum and energy.
- a) Both A and R are true and R is the correct explanation of A. b) Both A and R are true but R is not the correct explanation of A.
c) A is true but R is false. d) A is false but R is true.

18. **Assertion (A):** A soft iron core is used in a moving coil galvanometer to increase the strength of magnetic field. [1]
Reason (R): From soft iron more number of the magnetic lines of force passes.
- a) Both A and R are true and R is the correct explanation of A. b) Both A and R are true but R is not the correct explanation of A.
c) A is true but R is false. d) A is false but R is true.

Section B

19. Distinguish between a metal and an insulator on the basis of energy band diagram. [2]
20. At what speed must the electron revolve around the nucleus of the hydrogen atom so that it may not be pulled into the nucleus by electrostatic attraction ? Given $r = 0.5 \times 10^{-10}$ m, $m_e = 9.1 \times 10^{-31}$ kg and $e = 1.6 \times 10^{-19}$ C. [2]
21. Electromagnetic waves with wavelength [2]
- λ_1 , are used to treat muscular strain
 - λ_2 , are used by a FM radio station for broadcasting.
 - λ_3 , are used to detect fracture in bones
 - λ_4 , are absorbed by the ozone layer of the atmosphere.

Identify and name the part of electromagnetic spectrum to which these radiations belong. Arrange these wavelengths in decreasing order of magnitude.

OR

A capacitor of capacitance C is being charged by connecting it across a DC source along with an ammeter. Will the ammeter show a momentary deflection during the process of charging? If so, how would you explain this momentary deflection and the resulting continuity of current in the circuit? Write the expression for the current inside the capacitor.

22. Name the type of bias that results in very high resistance of a p-n junction diode. In the given circuit, a voltmeter V is connected across bulb B . What changes would occur in bulb B and voltmeter V , if the resistor R is increased in value? Give reason for your answer. [2]
23. Calculate the potential at P due to the charge configuration as shown in the following figure. If $r \gg a$, then how will you modify the result? [2]

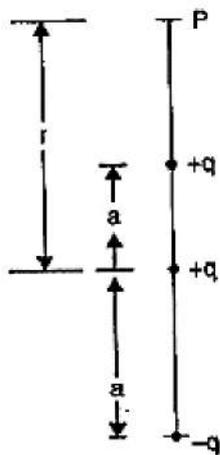

OR

In the given circuit, with a steady current, calculate the potential difference across the capacitor and the charge stored in it.

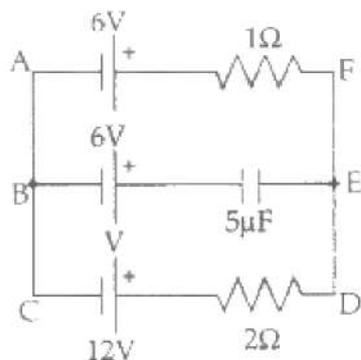

24. Draw a graph showing the variation of stopping potential with frequency of the incident radiation. What does the slope of the line with frequency axis indicate? [2]
25. Why is it necessary to slow down the neutrons, produced through the fission of ${}_{92}^{235}\text{U}$ nuclei (by neutrons), to sustain a chain reaction? What type of nuclei are (preferably) needed for slowing down fast neutrons? [2]

Section C

26. State Bohr's quantization condition of angular momentum. Calculate the shortest wavelength of the Brackett series and state to which part of the electromagnetic spectrum does it belong. [3]
27. Explain how Newton's Corpuscular theory predicts the speed of light in a medium, say water, to be greater than the speed of light in vacuum. Is the prediction confirmed by the experimental determination of speed of light in water? If not, which alternative picture of light is consistent with experiment? [3]
28. The current through two inductors of self-inductance 12 mH and 30 mH is increasing with time at the same rate. [3]
Draw graphs showing the variation of the:
i. emf induced with the rate of change of current in each inductor.
ii. energy stored in each inductor with the current flowing through it.
Compare the energy stored in the coils, if the powers dissipated in the coils are same.

OR

- a. A toroidal solenoid with an air core has an average radius of 0.15 m, area of cross section $12 \times 10^{-4} \text{m}^2$ and 1200 turns. Obtain the self inductance of the toroid. Ignore field variation across the cross section of the toroid.
- b. A second coil of 300 turns is wound closely on the toroid above. If the current in the primary coil is increased from zero to 2.0 A in 0.05 s, obtain the induced emf in the secondary coil.
29. i. Why is the thin ozone layer on top of the stratosphere crucial for human survival? Identify to which part of [3]

- the electromagnetic spectrum does this radiation belong and write one important application of the radiation.
- ii. Why are infrared waves referred to as heatwaves? How are they produced? What role do they play in maintaining the earth's warmth through the greenhouse effect?

OR

The oscillating magnetic field in a plane electromagnetic wave is given by

$$B_y = (8 \times 10^{-6}) \sin[2 \times 10^{11}t + 300\pi x]T$$

- i. Calculate the wavelength of the electromagnetic wave.
 - ii. Write down the expression for the oscillating electric field.
30. What are paramagnetic substances? Explain the origin of paramagnetism. [3]

Section D

31. Using Gauss' law, deduce the expression for the electric field due to a uniformly charged spherical conducting shell of radius R at a point [5]
- i. outside the shell
 - ii. inside the shell

Plot a graph showing a variation of the electric field as a function of $r > R$ and $r < R$ (r being the distance from the centre of the shell).

OR

Two equal positive charges, each of $2 \mu C$ interact with a third positive charge of $3 \mu C$ situated as shown in Fig. Find the magnitude and direction of the force experienced by the charge of $3 \mu C$.

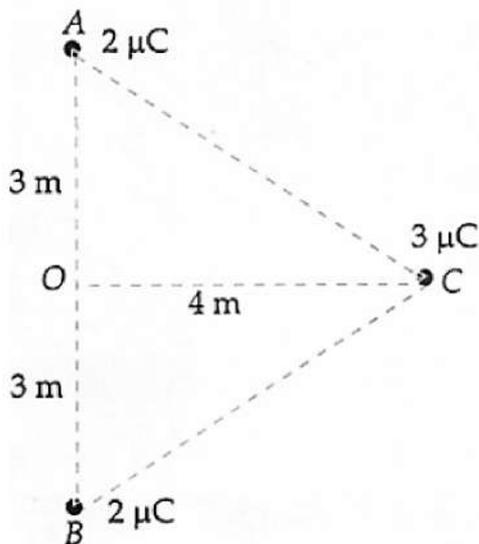

32. i. Draw a labelled ray diagram showing the image formation of a distant object by a refracting telescope. Deduce the expression for its magnifying power when the final image is formed at infinity. [5]
- ii. The sum of focal lengths of the two lenses of a refracting telescope is 105 cm. The focal length of one lens is 20 times that of the other. Determine the total magnification of the telescope when the final image is formed at infinity.

OR

- i. Draw the ray diagram of an astronomical telescope when the final image is formed at infinity. Write the expression for the resolving power of the telescope.
- ii. An astronomical telescope has an objective lens of focal length 20 m and eyepiece of focal length 1 cm.
 - a. Find the angular magnification of the telescope.

b. If this telescope is used to view the Moon, find the diameter of the image formed by the objective lens. Given the diameter of the Moon is 3.5×10^6 m and radius of the lunar orbit is 3.8×10^8 m.

33. a. Estimate the average drift speed of conduction electrons in a copper wire of cross-sectional area 1.0×10^{-7} m² carrying a current of 1.5 A. Assume that each copper atom contributes roughly one conduction electron. The density of copper is 9.0×10^3 kg/m³, and its atomic mass is 63.5 u. [5]
- b. Compare the drift speed obtained above with,
- thermal speeds of copper atoms at ordinary temperatures,
 - speed of propagation of electric field along the conductor which causes the drift motion.

Section E

34. **Read the text carefully and answer the questions:** [4]

The path of a charged particle in magnetic field depends upon angle between velocity and magnetic field. If velocity \vec{v} is at angle θ to \vec{B} , component of velocity parallel to magnetic field ($v \cos \theta$) remains constant and component of velocity perpendicular to magnetic field ($v \sin \theta$) is responsible for circular motion, thus the charge particle moves in a helical path.

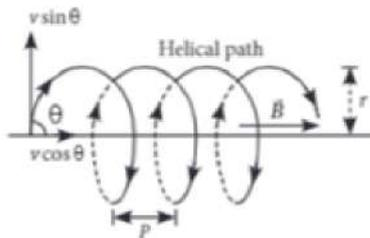

The plane of the circle is perpendicular to the magnetic field and the axis of the helix is parallel to the magnetic field. The charged particle moves along helical path touching the line parallel to the magnetic field passing through the starting point after each rotation.

Radius of circular path is $r = \frac{mv \sin \theta}{qB}$

Hence the resultant path of the charged particle will be a helix, with its axis along the direction of \vec{B} as shown in figure.

- What will be the trajectory of a positively charged particle if it enters into a uniform magnetic field with uniform velocity at right angle to the magnetic field?
- Two charged particles A and B having the same charge, mass and speed enter into a magnetic field in such a way that the initial path of A makes an angle of 30° and that of B makes an angle of 90° with the field. Find the ratio of radii of circular path covered by particles A and B?
- An electron having momentum 2.4×10^{-23} kg m/s enters a region of uniform magnetic field of 0.15 T. The field vector makes an angle of 30° with the initial velocity vector of the electron. What will be the radius of the helical path of the electron in the field ?

OR

The magnetic field in a certain region of space is given by $B = 8.35 \times 10^{-2} \hat{i}$ T. A proton is shot into the field with velocity $\vec{v} = (2 \times 10^5 \hat{i} + 4 \times 10^5 \hat{j})$ m/s. The proton follows a helical path in the field. What will be the distance moved by proton in the x-direction during the period of one revolution in the yz-plane? (Mass of proton = 1.67×10^{-27} kg)

35. **Read the text carefully and answer the questions:**

[4]

A transformer is essentially an a.c. device. It cannot work on d.c. It changes alternating voltages or currents. It does not affect the frequency of a.c. It is based on the phenomenon of mutual induction. A transformer essentially consists of two coils of insulated copper wire having a different number of turns and wound on the same soft iron core.

The number of turns in the primary and secondary coils of an ideal transformer are 2000 and 50 respectively.

The primary coil is connected to the main supply of 120 V and secondary coil is connected to a bulb of resistance 0.6Ω .

- (i) What will be the value of voltage across the secondary coil?
- (ii) Find the value of the current in the bulb.
- (iii) What will be the value of current in the primary coil?

OR

Calculate the power in primary coil.

Solution
SAMPLE PAPER - 5
Class 12 - Physics

Section A

1. (a) number of electrons and holes increase equally

Explanation: Due to heating, when a free electron is produced, then simultaneously a hole is also produced.

2. (d) 100 Ω

Explanation: The terminal potential difference across R due to 12 volt battery should be equal to 2 V which is the emf of the cell in the loop containing the ammeter.

$$\text{So, } 12 - \frac{12}{500 + R} \times 500 = 2$$

$$10 = \frac{12 \times 500}{500 + R} \text{ or } 500 + R = 600 \text{ or } R = 100 \Omega$$

3. (c) a real, inverted, same-sized image can be formed using a convex mirror

Explanation: The convex mirror always forms, virtual, erect, and smaller images.

4. (b) Holes are the majority carriers and trivalent atoms are the dopants.

Explanation: In a p-type semiconductor, an intrinsic semiconductor is doped with trivalent impurities, which creates deficiencies of valence electrons called holes which are majority charge carriers.

5. (c) $\frac{(V_0 - V)}{V}$

Explanation: Common potential

$$V = \frac{C_1 V_1 + C_2 V_2}{C_1 + C_2}$$

$$= \frac{0 + CV_0}{\kappa C + C} = \frac{CV_0}{C(1 + \kappa)} = \frac{V_0}{1 + \kappa}$$

6. (b) low resistance in parallel

Explanation: To convert a galvanometer into an ammeter, we connect a low resistance in parallel with it.

7. (a) 12 V

Explanation: Since,

$$e = \frac{d\phi}{dt} \text{ (in magnitude)}$$

$$= 10t + 2$$

$$\text{when } t = 1 \text{ s, then } e = 12 \text{ V}$$

8. (c) -11.4 eV

Explanation: Given, $\mathcal{E} = 0.1$, $R_0 = 0.1 \text{ \AA}$

$$\text{Let } \varepsilon = 2 + \delta$$

$$\frac{q_1 q_2}{4\pi\epsilon_0} = (1.6 \times 10^{-19})^2 (9 \times 10^9)$$

$$= 2.3 \times 10^{-28} \text{ Nm}^2$$

$$\left(\frac{1}{R_0^2}\right) \left(\frac{R_0}{r}\right)^\varepsilon = \left(\frac{1}{R_0^2}\right) \left(\frac{R_0}{r}\right)^{2+\delta}$$

$$= \frac{R_0^\delta}{r^{2+\delta}} \dots \left(\because x = \frac{q_1 q_2}{4\pi\epsilon_0}\right)$$

$$\text{Thus, } F = \frac{x R_0^\delta}{r^{2+\delta}}$$

$$\text{As } F = \frac{mv^2}{r}$$

$$\Rightarrow \frac{mv^2}{r}$$

$$= \frac{x R_0^\delta}{r^{2+\delta}}$$

$$\text{or } v^2 = \frac{x R_0^\delta}{mr^{1+\delta}} \dots(i)$$

i. As we know that,

$$\text{As } mvr = nh$$

$$\Rightarrow r = \frac{nh}{mv}$$

using equation (i), $r = \frac{nh}{m} \left[\frac{m}{xR_0^\delta} \right]^{1/2} r^{\frac{1+\delta}{2}}$

or, $r^{(1-\delta)/2} = \left(\frac{n^2 h^2}{mxR_0^\delta} \right)^{1/2} \dots \left(\because r = \left(\frac{n^2 h^2}{mxR_0^\delta} \right)^{1/(1-\delta)} \right)$

For $n = 1$,

$$r_1 = \left(\frac{h^2}{mxR_0^\delta} \right)^{1/(1-\delta)}$$

$$= \left[\frac{(1.05 \times 10^{-34})^2}{(9.1 \times 10^{-31})(2.3 \times 10^{-28})(10^{19})} \right]^{\frac{1}{29}}$$

$$= 8 \times 10^{-11} \text{ m}$$

$$= 0.8 \text{ \AA}$$

ii. We know,

From $v_n = \frac{nh}{mr_n}$

$$= nh \left(\frac{xR_0^\delta}{n^2 h^2} \right)^{\frac{1}{1-\delta}}$$

For $n = 1$,

$$v_1 = \frac{h}{mr_1}$$

$$= 1.44 \times 10^6 \text{ ms}^{-1}$$

iii. Kinetic Energy is,

$$\text{K.E.} = \frac{1}{2} m v_1^2$$

$$= 9.43 \times 10^{-19} \text{ J}$$

$$= 5.9 \text{ eV}$$

iv. Potential Energy of electron from ∞ to R_0

$$U_1 = \frac{1}{4\pi\epsilon_0} \left(\frac{q_1 q_2}{R_0} \right)$$

$$= \frac{-x}{R_0}$$

Potential Energy, of electron from R_0 to r

$$U_2 = - \int_{R_0}^r F dr$$

$$= x R_0^\delta \int_{R_0}^r \frac{dr}{r^{2+\delta}}$$

$$= \frac{x R_0^\delta}{r^{1+\delta}} \left[\frac{1}{r^{1+\delta}} \right]_{R_0}^r$$

$$= \frac{-x}{(1+\delta)} \left[\frac{R_0^\delta}{r^{1+\delta}} - \frac{1}{R_0} \right]$$

Total Potential Energy of electron, P.E.

$$= - \frac{x}{1+\delta} \left[\frac{R_0^\delta}{r^{1+\delta}} - \frac{1}{R_0} + \frac{1+\delta}{R_0} \right]$$

$$= \frac{-2.3 \times 10^{-28}}{0.9} \left[\frac{R_0^\delta}{r^{1+\delta}} - \frac{\delta}{R_0} \right]$$

$$= \frac{-2.3 \times 10^{-28}}{0.9} \left[\frac{R_0^{-19}}{r^{-0.9}} - \frac{1.9}{R_0} \right]$$

$$= \frac{-2.3 \times 10^{-28}}{-0.9} \left[\frac{(0.8)^{0.9}}{10^{-10 \times (-1.9)}} - \frac{1.9}{10^{-10}} \right]$$

$$= \frac{2.3 \times 10^{-28}}{0.9 \times 10^{-10}} [(0.8)^{0.9} - 1.9]$$

$$= -17.3 \text{ eV}$$

Total energy, $E = \text{K.E.} + \text{P.E.}$

$$= 5.9 \text{ eV} + 17.3 \text{ eV}$$

$$= -11.4 \text{ eV}$$

9. (a) $\sqrt{\frac{5}{2}}$

Explanation: $PQ = QR = 2h \Rightarrow \angle i = 45^\circ$

$\therefore ST = RT = h = KM = MN$

So, $KS = \sqrt{h^2 + (2h)^2} = h\sqrt{5}$

$$\therefore \sin r = \frac{h}{h\sqrt{5}} = \frac{1}{\sqrt{5}}$$

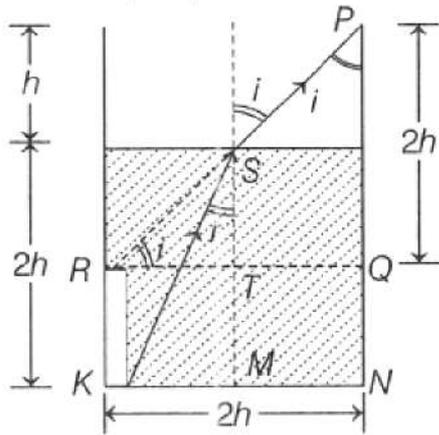

$$\therefore \mu = \frac{\sin i}{\sin r} = \frac{\sin 45^\circ}{1/\sqrt{5}} = \sqrt{\frac{5}{2}}$$

10. (d) 6.25×10^{18}

Explanation: $n = \frac{q}{e} = \frac{1C}{1.6 \times 10^{-19}C}$
 $= 6.25 \times 10^{18}$

11. (c) p-type crystal

Explanation: When we connect p-type region of a junction with the positive terminal of a voltage source and n-type region with the negative terminal of the voltage source, then the junction is said to be forward biased.

12. (b) 40 cm

Explanation:

To obtain, an inverted and equal size image, the object must be paced at a distance of $2f$ from the lens, i.e., 40 cm in this case.

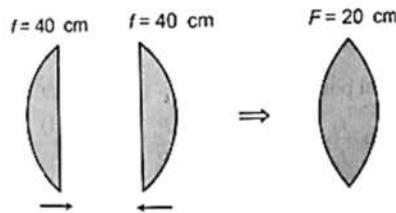

13. (a) 4λ

Explanation: $eV = hc \left(\frac{1}{\lambda} - \frac{1}{\lambda_0} \right) \dots(i)$

$\frac{eV}{3} = hc \left(\frac{1}{2\lambda} - \frac{1}{\lambda_0} \right) \dots(ii)$

Dividing eqn. (i) by (ii), we get;

$$3 = \frac{\left(\frac{1}{\lambda} - \frac{1}{\lambda_0} \right)}{\left(\frac{1}{2\lambda} - \frac{1}{\lambda_0} \right)}$$

or $3 \left(\frac{1}{2\lambda} - \frac{1}{\lambda_0} \right) = \frac{1}{\lambda} - \frac{1}{\lambda_0}$

or $\frac{3}{2\lambda} - \frac{1}{\lambda} = \frac{3}{\lambda_0} - \frac{1}{\lambda_0} = \frac{2}{\lambda_0}$

or $\frac{1}{2\lambda} = \frac{2}{\lambda_0}$ or $\lambda_0 = 4\lambda$

14. (d) depend on the radii of the sphere

Explanation: As potential on the surface of conducting sphere is given by

$V = \frac{q}{4\pi\epsilon_0 R}$ thus if q is same for both the sphere

$V \propto \frac{1}{R}$.

15. (c) 12

Explanation: add explanation here

16. (a) Assertion and reason both are correct statements and reason is correct explanation for assertion.

Explanation: Assertion and reason both are correct statements and reason is correct explanation for assertion.

17. (a) Both A and R are true and R is the correct explanation of A.

Explanation: An em wave carries momentum. When it falls on a surface, it exerts pressure called radiation pressure.

18. (a) Both A and R are true and R is the correct explanation of A.

Explanation: A soft iron core increase the strength of magnetic field, by forcing large number of magnetic lines through the soft iron core, which in turn increases the sensitivity of the galvanometer.

Section B

19. **Metals:** The energy band structure in solids have two possibilities:

(i) The valence band may be completely filled and the conduction band partially filled with an extremely small energy gap between them [Fig a(i)]

(ii) The valence band is completely filled and the conduction band is empty but the two overlap each other [Fig a(ii)].

In both situations, it can be assumed that there is a single energy band, which is partially filled. Therefore, on applying even a small electric field, the metals conduct electricity.

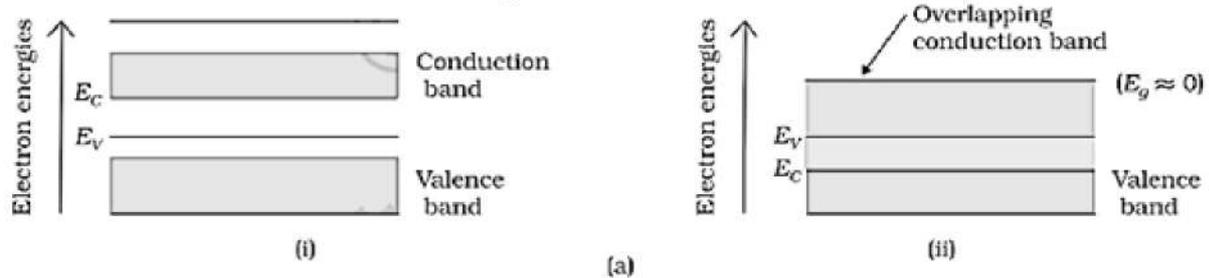

Insulators: In insulators, as shown in Fig. (b), a large band gap E_g exists ($E_g > 3 \text{ eV}$). There are no electrons in the conduction band, and therefore no electrical conduction is possible. Note that the energy gap is so large that electrons cannot be excited from the valence band to the conduction band by thermal excitation.

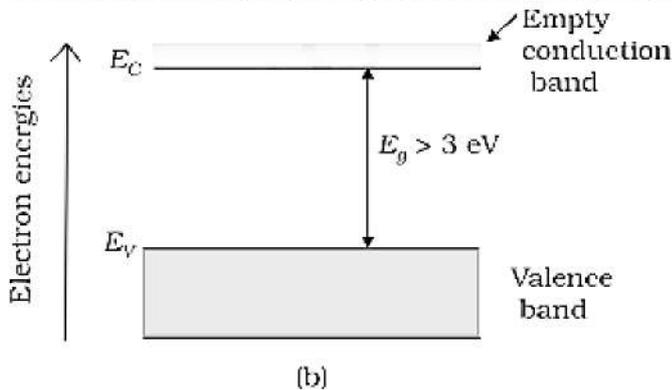

20. Here $\frac{mv^2}{r} = k \frac{q_1 q_2}{r^2}$
 or $v^2 = k \frac{q_1 q_2}{mr} = \frac{9 \times 10^9 \times 1.6 \times 10^{-19} \times 1.6 \times 10^{-19}}{9.1 \times 10^{-31} \times 0.5 \times 10^{-10}}$
 $= \frac{4.8 \times 10^6}{\sqrt{4.55}} \text{ ms}^{-1}$
 $v = 2.25 \times 10^6 \text{ ms}^{-1}$

21. i. λ_1 belongs to Infrared radiations.
 ii. λ_2 belongs to UHF radiowaves.
 iii. λ_3 belongs to X-rays.
 iv. λ_4 belongs to ultraviolet rays.

The arrangement of wavelengths in decreasing order of magnitude are $\lambda_2 > \lambda_1 > \lambda_4 > \lambda_3$.

OR

Yes, the ammeter will show the momentary deflection.

This momentary deflection occurs due to the fact that the conducting current flows through connecting wires during the charging of capacitor. This leads to deposition of charge at two plates and hence, varying electric field of increasing nature is produced between the plates which in turn produces displacement current in space between two plates, which maintains the continuity with the conduction current.

The current inside the capacitor is

$$I = \epsilon_0 \frac{d\phi_E}{dt}, \text{ where } \frac{d\phi_E}{dt} \text{ is the rate of change of electric flux with time.}$$

22. The reverse biasing results in very high resistance across the p-n junction.

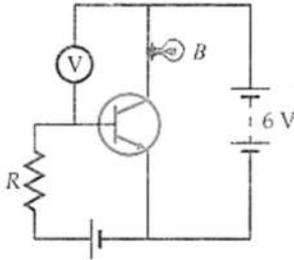

If the value of the resistance R is increased, the current in the forward-biased input circuit decreases. The emitter current I_E decreases and hence the collector current ($I_C = I_E - I_B$) also decreases. The glowness of the bulb decreases. Due to the decrease in I_C , the potential drop across bulb B decreases, and hence the voltmeter shows a lower voltage.

23. Potential at P due to the given charge configuration is the sum of the potentials due to charges $-q$, $+q$ and $+q$. These charges are at distances $r+a$, r and $r-a$ respectively from the point P.

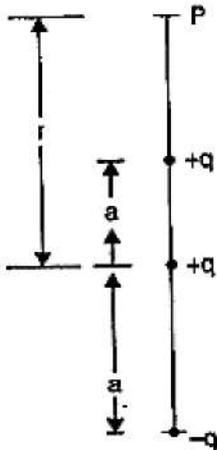

$$\therefore V = \frac{1}{4\pi\epsilon_0} \frac{-q}{(r+a)} + \frac{1}{4\pi\epsilon_0} \frac{q}{r} + \frac{1}{4\pi\epsilon_0} \frac{q}{r-a}$$

$$V = \frac{1}{4\pi\epsilon_0} \left(\frac{q}{r} + \frac{2qa}{r^2 - a^2} \right)$$

If $r \gg a$, then $r^2 - a^2 = r^2$

$$\therefore V = \frac{1}{4\pi\epsilon_0} \left(\frac{q}{r} + \frac{2qa}{r^2} \right)$$

OR

this problem is solved by using kirchoff's rule thus

In the loop ACDEFA

$$I = \frac{12-6}{(1+2)} = 2A$$

Applying KVI in the loop BEDCB, we get

let the potential drop across the capacitor is V_C

$$V_C + 6 - 12 + 2 \times 2 = 0$$

$$V_C = 2V$$

Charge on capacitor is $Q = CV_C = 5 \mu F \times 2V$

$$= 10 \mu C$$

24. The variation between stopping potential V_0 and frequency ν of the incident radiation on a photosensitive surface is a straight line AB as shown in Fig.

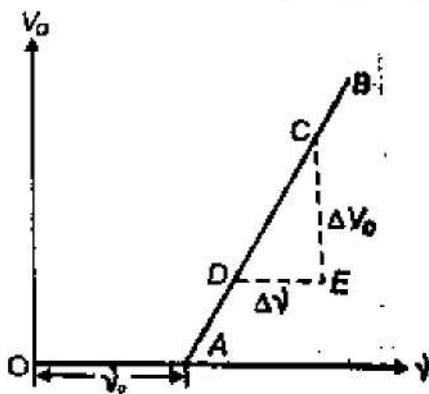

Here, slope of line $AB = \frac{\Delta V_0}{\Delta \nu}$

From Einstein photoelectric equation, $eV_0 = h\nu - \phi_0$

Differentiating it, we get $e\Delta V_0 = h\Delta \nu$ or $\frac{\Delta V_0}{\Delta \nu} = \frac{h}{e}$

Thus, slope of the line $AB = \frac{\Delta V_0}{\Delta \nu} = \frac{h}{e}$

here h is Planck's constant and e is the electronic charge.

25. It is necessary to slow down the neutrons, produced through the fission of ${}_{92}^{235}\text{U}$ nuclei (by neutrons), to sustain a chain reaction since slow neutrons have a much higher intrinsic probability of inducing fission in ${}_{92}^{235}\text{U}$ than fast neutrons. Any substance which is used to slow down fast moving neutrons to thermal energies is called a moderator. Moderators are provided along with the fissionable nuclei for slowing down fast neutrons. The commonly used moderators are water, heavy water (D_2O) and graphite.

Section C

26. **Bohr's quantization condition of angular momentum:** According to Bohr, the electron can revolve in certain discrete orbits called stationary orbits. The total angular momentum (L) of the revolving electron is an integral multiple of $\frac{h}{2\pi}$.

Thus, angular momentum, $L = mvr = \frac{nh}{2\pi}$

where $n = 1, 2, 3, \dots$

Brackett series is obtained when an electron jumps to fourth orbit ($n_1 = 4$) from any outer orbit ($n_2 = 5, 6, 7, \dots$) of the hydrogen atom.

The wavelength of a spectral line is given as

$$\frac{1}{\lambda} = RZ \left(\frac{1}{n_1^2} - \frac{1}{n_2^2} \right)$$

where R is Rydberg's constant ($1.097 \times 10^7 \text{ m}^{-1}$) and Z is the atomic number ($Z = 1$ for hydrogen atom). For Brackett series, $n_1 = 4$ and $n_2 = 5, 6, 7, \dots$

Therefore,

$$\frac{1}{\lambda} = R \left(\frac{1}{4^2} - \frac{1}{n_2^2} \right)$$

For the shortest wavelength, $n_2 = \infty$. Therefore,

$$\frac{1}{\lambda} = R \left[\frac{1}{4^2} - \frac{1}{\infty^2} \right] = R \left(\frac{1}{4^2} - 0 \right)$$

$$\frac{1}{\lambda} = \frac{R}{16} = \frac{1.097 \times 10^7}{16}$$

$$\Rightarrow \lambda = \frac{16}{1.097 \times 10^7} = 14.585 \times 10^{-7}$$

or $\lambda = 1458.5 \text{ nm}$.

The shortest wavelength of the Brackett series is 1458.5 nm.

This wavelength belongs to infrared range of electromagnetic spectrum.

27. According to Newton's Corpuscular theory of light, when corpuscles of light strike the interface XY , figure separating a denser medium from a rarer medium, the component of their velocity along XY remains the same.

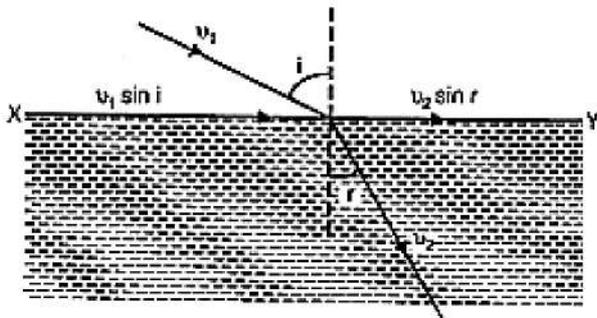

If v_1 is velocity of light in rarer medium (air),
 v_2 is velocity of light in denser medium (water),
 i is the angle of incidence,
 r is angle of refraction,
 Then component of v_1 along XY = $v_1 \sin i$
 Component of v_2 along XY = $v_2 \sin r$

As $v_1 \sin i = v_2 \sin r$

$$\therefore \frac{v_2}{v_1} = \frac{\sin i}{\sin r} = \mu$$

As $\mu > 1 \therefore v_2 > v_1$

i.e. light should travel faster in water than in air. This prediction of Newton's theory is opposite to the experiment result. Huygens wave theory predicts that $v_2 < v_1$, which is consistent with experiment.

28. Here $L_1 = 12 \text{ mH} = 12 \times 10^{-3} \text{ H}$

$L_2 = 30 \text{ mH} = 30 \times 10^{-3} \text{ H}$

i. As current is increasing at the same rate $\frac{dI}{dt}$, e.m.f. induced opposed the increase.

$$e_1 = L_1 \frac{dI}{dt} = 12 \times 10^{-3} \frac{dI}{dt}$$

$$e_2 = L_2 \frac{dI}{dt} = 30 \times 10^{-3} \frac{dI}{dt}$$

The variation of e with $\frac{dI}{dt}$ is as shown in fig:

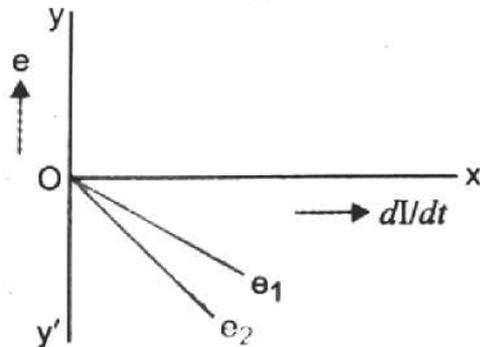

ii. Energy stored $E = \frac{1}{2} LI^2$

For given L , $E \propto I^2$, therefore, variation of energy stored with the current is as shown in fig.

Power dissipated,

$$P = \frac{dE}{dt} = \frac{d}{dt} \left(\frac{1}{2} LI^2 \right)$$

$$= LI \frac{dI}{dt} = \left(\frac{L dI}{dt} \right) I = e \cdot I = \text{const.}$$

As $e_2 > e_1$

$\therefore I_2 < I_1$

\therefore thus the energy stored is given by $\frac{E_2}{E_1} = \frac{\frac{1}{2} L_2 I_2^2}{\frac{1}{2} L_1 I_1^2} = \frac{L_2}{L_1} \left(\frac{I_2}{I_1} \right)^2 = \frac{30}{12} \left(\frac{12}{30} \right)^2$

$$= \frac{12}{30} = \frac{2}{5} = 0.4$$

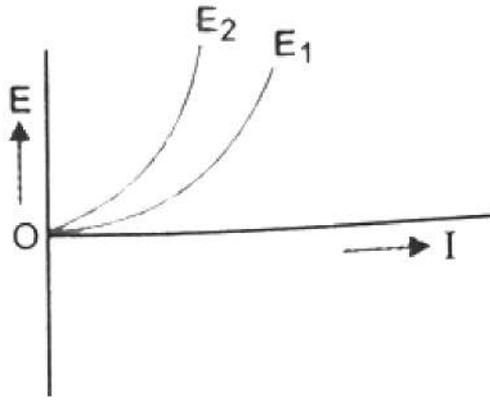

OR

$$a. B = \mu_0 n_1 I = \frac{\mu_0 N_1 I}{l} = \frac{\mu_0 N_1 I}{2\pi r}$$

$$\text{Total magnetic flux, } \phi_B = N_1 BA = \frac{\mu_0 N_1^2 IA}{2\pi r}$$

$$\text{But } \phi_B = LI$$

$$\therefore L = \frac{\mu_0 N_1^2 A}{2\pi r}$$

$$\text{Or } L = \frac{4\pi \times 10^{-7} \times 1200 \times 1200 \times 12 \times 10^{-4}}{2\pi \times 0.15}$$

$$= 2.3 \times 10^{-3} H = 2.3 \text{ mH}$$

$$b. |E| = \frac{d}{dt}(\phi_2) \text{ where } \phi_2 \text{ is the total magnetic flux linked with the second coil.}$$

$$|E| = \frac{d}{dt}(N_2 BA) = \frac{d}{dt} \left[N_2 \frac{\mu_0 N_1 I}{2\pi r} A \right]$$

$$|E| = \frac{\mu_0 N_1 N_2 A}{2\pi r} \frac{dI}{dt}$$

$$|E| = \frac{4\pi \times 10^{-7} \times 1200 \times 300 \times 12 \times 10^{-4} \times 2}{2\pi \times 0.15 \times 0.05} = 0.023 \text{ V}$$

29. i. It absorbs ultraviolet radiation from the sun and prevents them from reaching on the earth's surface causing damage to life. In the electromagnetic spectrum, ultraviolet radiations occur in between visible light and x-rays.

Identification: Ultraviolet radiations

application: Ultraviolet radiations are used to destroy the harmful bacteria and for sterilizing the surgical instruments.

- ii. Water molecules present in most materials readily absorb infrared waves. Hence, their thermal motion increases, therefore, they heat their surroundings.

They are produced by hot bodies and molecules. Incoming visible light is absorbed by the earth's surface and radiated as infrared radiations. These radiations are trapped by greenhouse gases.

OR

Given equation is:

$$B_y = (8 \times 10^{-6}) \sin[2 \times 10^{11}t + 300\pi x] T$$

- i. Comparing the given equation with the equation of magnetic field varying sinusoidally with x and t,

$$B_y = B_0 \sin\left(\frac{2\pi x}{\lambda} + \frac{2\pi t}{T}\right), \text{ we get}$$

$$\frac{2\pi}{\lambda} = 300\pi$$

Thus, the wavelength of the electromagnetic wave is,

$$\lambda = \frac{2}{300} = 0.0067 \text{ m}$$

- ii. $B_0 = 8 \times 10^{-6} T$

$$E_0 = cB_0 = 3 \times 10^8 \times 8 \times 10^{-6}$$

$$= 24 \times 10^2 = 2400 \text{ V m}^{-1}$$

\therefore The required expression for the oscillating electric field is,

$$E_z = E_0 \sin\left(\frac{2\pi x}{\lambda} + \frac{2\pi t}{T}\right)$$

$$= 2400 \sin(300\pi x + 2 \times 10^{11}t) \text{ V/m}$$

30. **Paramagnetic substances:** Paramagnetic substances are those which develop feeble magnetisation in the direction of the magnetising field. Such substances are feebly attracted by magnets and tend to move from weaker to stronger parts of a magnetic field.

Origin of paramagnetism: According to Langevin, the atoms or molecules of a paramagnetic material possess a permanent magnetic moment either due to the presence of some unpaired electron or due to the non-cancellation of the spins of two electrons

because of some special reason. In the absence of an external magnetic field, the atomic dipoles are randomly oriented due to their ceaseless random motion, as shown in figure (a). There is no net magnetisation.

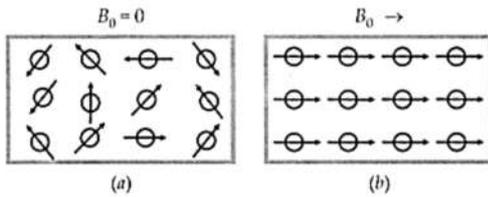

When a strong enough field \vec{B}_0 , is applied and the temperature is low enough, the field \vec{B}_0 tends to align the atomic dipoles in its own direction, producing a weak magnetic moment in the direction of \vec{B}_0 . The material tends to move from a weak field region to a strong field region. This is paramagnetism.

At very high magnetic fields or at very low temperatures, the magnetisation approaches its maximum value when all the atomic dipole moments get aligned. This is called the saturation magnetisation value M_s .

Section D

31. Electric field due to a uniformly charged thin spherical shell:

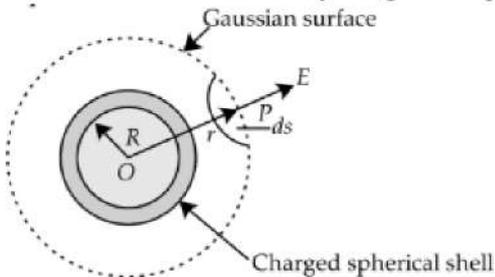

i. **When point P lies outside the spherical shell:** Suppose that we have to calculate electric field at the point P at a distance r ($> R$) from its centre.

Let \vec{E} be the electric field at point P, then the electric flux through area element $d\vec{S}$ is given by,

$$\Delta\phi = \vec{E} \cdot \Delta\vec{S}$$

Since $\Delta\vec{S}$ is also along normal to the surface,

$$\Delta\phi = EdS$$

\therefore Total electric flux through the Gaussian surface is given by.

$$\phi = \oint EdS = E \oint dS$$

$$\text{Now, } \oint dS = 4\pi r^2$$

$$\therefore \phi = E \times 4\pi r^2 \dots\dots(i)$$

Since the charge enclosed by the Gaussian surface is q , according to the Gauss's law,

$$\phi = \frac{q}{\epsilon_0} \dots\dots(ii)$$

From equation (i) and (ii), we obtain

$$E \times 4\pi r^2 = \frac{q}{\epsilon_0}$$

$$E = \frac{1}{4\pi\epsilon_0} \cdot \frac{q}{r^2} \text{ (for } r > R)$$

ii. **When point P lies inside the spherical shell:** In such a case, the Gaussian surface encloses no charge. According to Gauss's law,

$$E \times 4\pi r^2 = 0$$

$$\text{i.e., } E = 0 \text{ (for } r < R)$$

A graph showing the variation of electric field as a function of r is shown in figure.

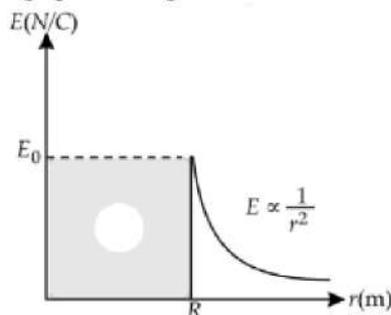

OR

Here $q_A = q_B = 2 \mu\text{C} = 2 \times 10^{-6} \text{ C}$,

$q_C = 3 \mu\text{C} = 3 \times 10^{-6} \text{ C}$

$AC = BC = \sqrt{3^2 + 4^2} = 5 \text{ m}$

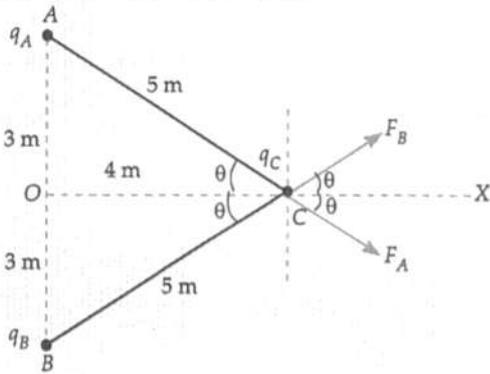

Force exerted by charge q_A on q_C ,

$$F_Z = \frac{1}{4\pi\epsilon_0} \frac{q_A q_C}{(AC)^2}$$

$$= \frac{9 \times 10^9 \times 2 \times 10^{-6} \times 3 \times 10^{-6}}{5^2}$$

$= 2.16 \times 10^{-3} \text{ N}$, along AC produced

Similarly, the force exerted by charge q_B on q_C

$F_B = 2.16 \times 10^{-3} \text{ N}$, along BC produced

Clearly, $F_A = F_B$ (in magnitude)

The components of F_A and F_B along the Y-axis will cancel out and get added along the X-axis.

\therefore Total force on $3 \mu\text{C}$ charge,

$$F = 2F_1 \cos \theta = 2 \times 2.16 \times 10^{-3} \times \frac{4}{5}$$

$= 3.456 \times 10^{-3} \text{ N}$, along CX.

32. i. ray diagram is given by;

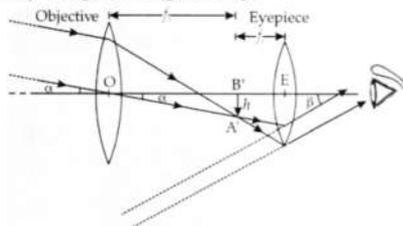

Magnifying power is given by ,

$$m = \frac{\tan \beta}{\tan \alpha} \cong \frac{\beta}{\alpha}$$

The angles are small

Final image is formed at infinity when the image $A'B'$ is formed by the objective lens at the focus of the eyepiece,

$$m = \frac{h}{f_e} \times \frac{f_0}{h}$$

$$m = \frac{f_0}{f_e}$$

ii. Given,

$$f_o + f_e = 105, f_o = 20f_e$$

$$20f_e + f_e = 105$$

$$f_e = \frac{105}{21} = 5 \text{ cm}$$

$$f_o = 20 \times 5 = 100 \text{ cm}$$

Magnification is given by, $m = \frac{f_o}{f_e} = \frac{100}{5} = 20$

OR

i.

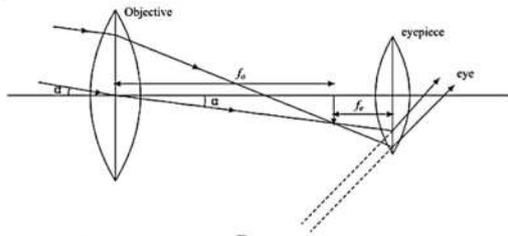

$$\text{Resolving power} = \frac{D}{1.22\lambda}$$

ii. a. Angular magnification $f_0 = 20 \text{ m}$, $f_e = 1 \text{ cm} = 0.01 \text{ m}$

$$m = \frac{f_0}{f_e}$$

$$m = \frac{20}{0.01} = 2000$$

b. Diameter of moon $= 3.5 \times 10^6 \text{ m}$ and radius of lunar orbit $= 3.8 \times 10^8 \text{ m}$. Let d be the diameter of the image in metres.

Then angle subtended by the moon will be

$$\alpha = \frac{\text{Diameter at moon}}{\text{Radius of lunar orbit}}$$

$$= \frac{3.5 \times 10^6}{3.8 \times 10^8}$$

Angle subtended by the image formed by the objective will also be equal to α and is given by

$$\alpha = \frac{\text{Diameter of image of moon}}{f_o}$$

$$\alpha = \frac{d}{20}$$

$$\therefore \frac{d}{20} = \frac{3.5 \times 10^6}{3.8 \times 10^8}$$

$$d = 0.18 \text{ m}$$

33. a. The direction of drift velocity of conduction electrons is opposite to the electric field direction, i.e., electrons drift in the direction of increasing potential. The drift speed v_d is given by Equation, $v_d = (I/neA)$ Now, $e = 1.6 \times 10^{-19} \text{ C}$, $A = 1.0 \times 10^{-7} \text{ m}^2$, $I = 1.5 \text{ A}$. The density of n conduction electrons, is equal to the number of atoms per cubic metre (assuming one conduction electron per Cu atom as is reasonable from its valence electron count of one). A cubic metre of copper has a mass of $9.0 \times 10^3 \text{ kg}$. Since 6.0×10^{23} copper atoms have a mass of 63.5 g ,

$$n = \frac{6.0 \times 10^{23}}{63.5} \times 9.0 \times 10^6$$

number of the conduction electron per unit volume is, $n = 8.5 \times 10^{28} \text{ m}^{-3}$

which gives,

$$v_d = \frac{1.5}{8.5 \times 10^{28} \times 1.6 \times 10^{-19} \times 1.0 \times 10^{-7}}$$

$$= 1.1 \times 10^{-3} \text{ m s}^{-1} = 1.1 \text{ mm s}^{-1}$$

b. i. At a temperature T , the thermal speed* of a copper atom of mass M is obtained from $\langle (\frac{1}{2}) Mv^2 \rangle = (3/2) k_B T$ and is thus typical of the order of $\sqrt{k_B T / M}$ (relation between velocity and temperature can be find by this relation), where k_B is the Boltzmann constant. For copper at 300 K , this is about $2 \times 10^2 \text{ m/s}$. There will be the random vibrational speeds of copper atoms in a conductor. Note that the drift speed of electrons is much smaller, about 10^{-5} times the typical thermal speed at ordinary temperatures.

ii. An electric field travelling along the conductor has a speed of an electromagnetic wave, namely equal to $3.0 \times 10^8 \text{ m s}^{-1}$.

The drift speed is, in comparison, extremely small; smaller by a factor of 10^{-11} . (speed must be less than speed of light)

Section E

34. Read the text carefully and answer the questions:

The path of a charged particle in magnetic field depends upon angle between velocity and magnetic field. If velocity \vec{v} is at angle θ to \vec{B} , component of velocity parallel to magnetic field ($v \cos \theta$) remains constant and component of velocity perpendicular to magnetic field ($v \sin \theta$) is responsible for circular motion, thus the charge particle moves in a helical path.

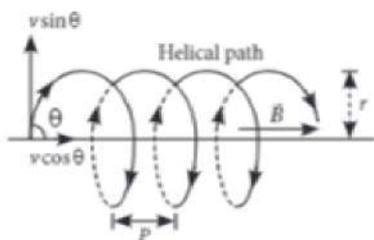

The plane of the circle is perpendicular to the magnetic field and the axis of the helix is parallel to the magnetic field. The charged particle moves along helical path touching the line parallel to the magnetic field passing through the starting point after each rotation.

Radius of circular path is $r = \frac{mv \sin \theta}{qB}$

Hence the resultant path of the charged particle will be a helix, with its axis along the direction of \vec{B} as shown in figure.

(i) The path of charged particle will be circular.

(ii) Using, $qvB \sin \theta = \frac{mv^2}{r}$

$r \propto \frac{1}{\sin \theta}$ for the same values of m, v, q and B

$$\therefore \frac{r_A}{r_B} = \frac{\sin 90^\circ}{\sin 30^\circ} = 2$$

(iii) The radius of the helical path of the electron in the uniform magnetic field is

$$r = \frac{mv_{\perp}}{eB} = \frac{mv \sin \theta}{eB} = \frac{(2.4 \times 10^{-23} \text{ kg m/s}) \times \sin 30^\circ}{(1.6 \times 10^{-19} \text{ C}) \times 0.15 \text{ T}}$$

$$= 5 \times 10^{-4} \text{ m} = 0.5 \times 10^{-3} \text{ m} = 0.5 \text{ mm}$$

OR

$$\text{Here, } \vec{B} = 8.35 \times 10^{-2} \hat{i} \text{ T}$$

$$\vec{v} = 2 \times 10^5 \hat{i} + 4 \times 10^5 \hat{j} \text{ m/s}$$

$$m = 1.67 \times 10^{-27} \text{ kg}$$

Pitch of the helix (i.e., the linear distance moved along the magnetic field in one rotation) is given by Pitch of the helix =

$$\frac{2\pi m v_1}{qB}$$

$$= \frac{2 \times 3.14 \times 1.67 \times 10^{-27} \times 2 \times 10^5}{1.6 \times 10^{-19} \times 8.35 \times 10^{-2}} = 0.157 \text{ m}$$

35. Read the text carefully and answer the questions:

A transformer is essentially an a.c. device. It cannot work on d.c. It changes alternating voltages or currents. It does not affect the frequency of a.c. It is based on the phenomenon of mutual induction. A transformer essentially consists of two coils of insulated copper wire having a different number of turns and wound on the same soft iron core.

The number of turns in the primary and secondary coils of an ideal transformer are 2000 and 50 respectively. The primary coil is connected to the main supply of 120 V and secondary coil is connected to a bulb of resistance 0.6Ω .

(i) As $\frac{E_s}{E_p} = \frac{n_s}{n_p} \Rightarrow E_s = E_p \cdot \frac{n_s}{n_p}$

$$= \frac{120 \times 50}{2000} = 3 \text{ V}$$

(ii) $I_s = \frac{E_s}{R} \Rightarrow I_s = \frac{3}{0.6} = 5 \text{ A}$

(iii) As $\frac{I_p}{I_s} = \frac{E_s}{E_p}$

$$\Rightarrow I_p = \frac{E_s}{E_p} \times I_s = \frac{3}{120} \times 5 = 0.125 \text{ A}$$

OR

$$\text{Power in primary, } P_p = E_p \times I_p = 120 \times 0.125 = 15 \text{ W}$$